

# Condenser Performance Solutions

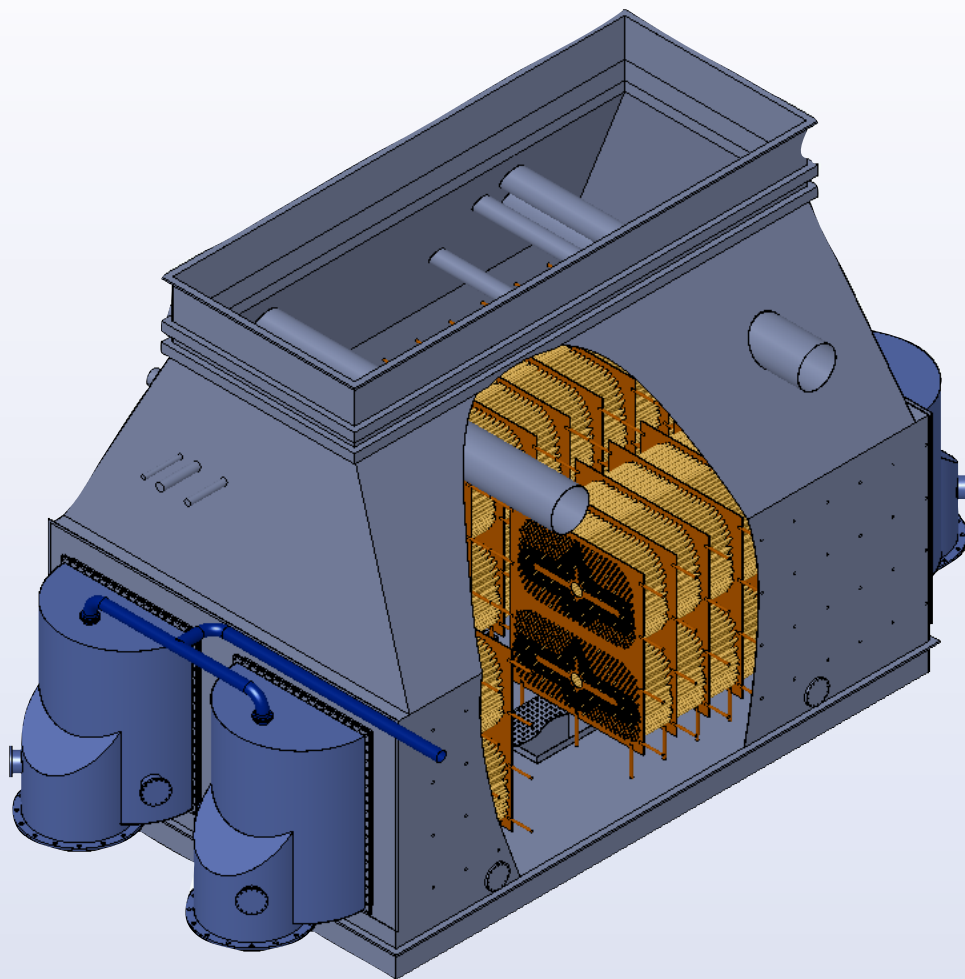

**Your gateway to improved condenser performance,  
fast response maintenance and  
optimized operations**

## Condenser Performance Services

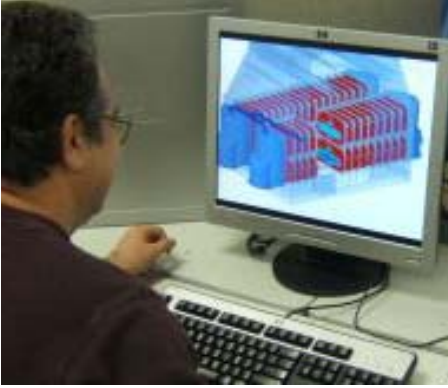

**Your Condenser Solutions Provider.** Intek manufactures instruments used to measure basic and advanced condenser operating parameters, provides services to guide selection of actionable items for achieving and maintaining maximum condenser performance, and engineers solutions to remedy unsolved condenser problems.

**Unique Condenser Instruments.** Accurate and reliable measurement of process conditions is the cornerstone of any diagnostic or troubleshooting effort. Intek's approach of integrating technologies to solve complex measurement problems has led to the development of unique instrumentation for monitoring and analyzing condenser performance. These instruments provide useful and otherwise unobtainable data on excess non-condensable gases, exhauster capacity, circulating water flow, and tube fouling, data needed to comprehensively quantify and monitor condenser performance.

Intek's patented *RheoVac*<sup>®</sup> and *Rheotherm*<sup>®</sup> instruments are in use around the world. Our experts possess an exclusive comprehension of condenser performance because of these one-of-a-kind instruments. Data from these and other instruments in hundreds of installations around the world have been used to gain a unique perspective of steam surface condensers and the condensation process as measured in operating units.

**Advanced Performance Analytics.** Intek has advanced the understanding of condenser performance analysis by developing methods to identify individual root-cause mechanisms of excess backpressure, which historically have been lumped into one parameter – the cleanliness factor. These advanced methods point to identifiable sources of excess backpressure such as circulating water flow, micro and macro fouling, and air storage which can then be targeted for correction. Using this approach, Intek offers a well-rounded service portfolio designed to help customers develop a better understanding of advanced condenser performance, empowering them to troubleshoot and solve condenser problems with greater speed and accuracy than ever before.

Intek engineers serve as consultants to EPRI and also serve on the ASME Heat Exchanger Committee.

**Dramatic Performance Improvements.** Intek's condenser performance engineering services have successfully achieved lower operating pressures than original design values, significant reductions of condensate dissolved gases, and greatly increased immunity to air in-leakage up to exhauster capacity. Condenser retrofit projects by Intek have achieved actual values of 1.0"Hg lower condenser pressure, condensate dissolved oxygen under 5 ppb (before the condensate pump), immunity to air in-leakage of 80 SCFM, and 5 to 10MW of increased generation.

## Unique Instrumentation

**Knowledge is Power.** Intek's core strategy of integrating technologies to solve complex measurement problems has led to the development of unique instrumentation for monitoring and analyzing condenser performance. This innovative approach has allowed Intek to develop unique expertise and insight about condenser performance, the condensation process, and the effects of air and other non-condensable gases in steam surface condensers. Intek's expertise comes from examination and analysis of operating data measured by the patented *RheoVac* and *Rheotherm* condenser instruments installed around the world. These instruments have been used to show irrefutable evidence of poor equipment performance, quantify condenser configuration problems, and identify error in other plant measurements.

Accurate and reliable measurement is the cornerstone of any diagnostic or troubleshooting effort. Intek's instruments and services are designed to help operate the condenser reliably and efficiently by providing otherwise unavailable measurements.

***RheoVac* Monitors for Air In-leakage & Exhauster Capacity.** Intek's *RheoVac* instrument has revolutionized the evaluation of condenser performance and design. It provides continuous monitoring of condenser air in-leakage and exhauster capacity, providing a positive indication when air in-leakage exceeds the exhauster's capacity and begins causing excess backpressure on the turbine. (See *RheoVac* product summary sheet for additional information.)

***Rheotherm* Circulating Water Flow and Fouling Meters.** CWFF meters provide continuous flow rate and temperature measurement. They also provide the information required to identify and quantify micro and macro fouling as well as deficiencies in the tube heat exchanger configuration. When strategically installed by Intek, the sensor data is used to accurately quantify degradation mechanisms and separately identify important information necessary to improve under-performing condensers. (See CWFF product summary sheet for additional information.)

**Accurate Shell Pressure & Temperature.** Intek's PT probe for shell pressure and temperature allows the shell measurement to be made within the steam space, eliminating pressure differentials caused by the common practice of remotely mounting these instruments. An integrated temperature sensor is included for saturation pressure validation. These instruments are designed for long-term reliable use in steam surface condenser applications, new condenser commission testing, and condenser upgrade evaluations.

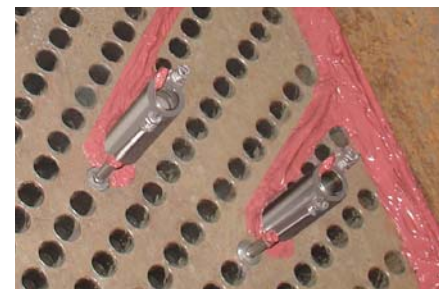

## RheoVac Monitors

The *RheoVac* instrument provides much more than an air in-leak measurement; it is the only instrument capable of analyzing the complex and dynamic nature of the mixture of non-condensable gases and vapor in the condenser vent line. This instrument is a true condenser monitor and provides the information needed to diagnose condenser performance issues and determine the adequacy of air removal equipment.

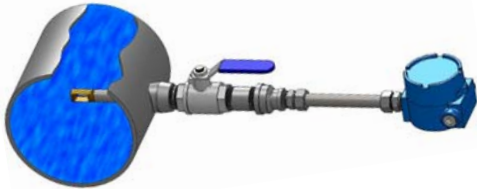

**Air In-Leakage.** The *RheoVac* instrument gives accurate measurement of air being removed from the condenser. By measuring air in-leakage flow between the condenser and the exhauster(s), a true reading of condenser air in-leakage passing through the condenser is made. A measurement made at the exhauster discharge is often inaccurate as it includes air in-leakage from exhauster seals and vent line isolation valves. Also, some exhauster outlet measurements require proper seating of a manually operated diverter valve, which can affect the reading.

**Exhauster Capacity.** If the exhauster equipment is degraded, a small amount of air in-leakage into the condenser can be a big problem. The *RheoVac* instrument provides a direct measurement of exhauster performance and shows if air in-leakage is affecting condenser performance. With this information, the identification of root causes for excess condenser pressure and condensate dissolved oxygen can be made. Intek has shown that standing rules-of-thumb, such as 1 SCFM per 100 MW or 10 SCFM maximum, are unsubstantiated guidelines that have been used because nothing better existed until now. Know, by direct measurement, that your exhauster is working properly!

**Water Vapor to Air Mass Ratio.** This direct reading of vacuum quality has resulted from *RheoVac* technology. It provides an early warning of the onset of excess backpressure caused by air in-leakage or exhauster degradation. It identifies the point at which standby exhausters are required, exhauster maintenance is needed, condenser air removal tube bundle sections are inadequate, or if existing leaks need to be repaired to prevent the onset of excess turbine back pressure.

**Water Carryover.** Entrained liquid phase water droplets in the condenser vent line is an unintended result of deficiency in condenser configuration or improper operations. Over-exhausting, improper vent line configuration, component failures and steam bypassing are among the possible causes for the existence of this condition. This condition negatively impacts the *RheoVac* instrument and indicates problems that should be addressed. Intek offers corrective devices that allow the instrument to function in such conditions until the root problem can be addressed.

## ***Rheotherm* Circulating Water Flow and Fouling (CWFF) Meter**

This product represents another breakthrough innovation from Intek in steam surface condenser instrumentation. By monitoring flow and temperature conditions of a selection of individual tubes, these meters allow early detection of tube corrosion and erosion mechanisms, identification of water and steam side heat transfer degradation mechanisms, monitoring waterbox fill level, and accurate online and offline tube cleaning evaluation. Typically, four to twelve sensors per outlet tube sheet provide substantial, continuous monitoring and diagnostic information about the entire tube bundle previously unattainable from available products.

**Flow Rate.** An array of sensors is installed in the outlet waterbox. The sensors are designed to attach to selected individual tubes, effectively providing individual tube flow information without obstructing water flow. The sensors use Intek's well-established *Rheotherm* technology to measure fluid temperature and flow parameters.

**Fouling, Erosion and Corrosion.** CWFF meters provide essential information for all heat exchanger or condenser monitoring and testing programs that demand high quality. They provide direct indication of the need for cleaning and the effectiveness of online cleaning methods, such as flow reversal. These sensors are highly recommended for heat exchangers and condensers prone to MIC attack, tube inlet erosion, particulate deposition, macrofouling (debris), microfouling, steam side ammonia grooving or high condensate dissolved oxygen. The information gained can quickly provide substantial financial return.

**Thermal Stratification.** Non-uniform service water flow or regional variations in condensing within the condenser can be detected as thermal stratification in the outlet waterbox with these sensors. Severe stratification is a sign of air storage caused by condenser configuration deficiencies. These pockets of air are the breeding ground for dissolved oxygen (DO) and excess condenser pressure.

**Modeling and Verification.** Intek has developed unique advanced condenser modeling tools capable of quantifying individual heat transfer degradation mechanisms and predicting the size and location of air bound regions caused by poor condenser configuration. The number and proper placement of CWFF meters is based on this modeling method.

**Solutions.** Measurement and verification of all condenser degradation mechanisms including air storage is the first step toward significant improvements in baseline condenser performance. Further model refinement is achieved by analyzing the sensor data over time. Intek's condenser engineering and retrofitting services can then be used to make permanent improvements to condenser performance.





## Pressure and Temperature Meters

**Accurate Saturated Steam Condition Measurement.** A recognized common problem with results from condenser performance assessments is the accuracy of condenser pressure measurement. While pressure transducers are well understood and typically provide reliable measurement at the sensing location, plant configurations connecting the condenser to the transducer, which is commonly located on the turbine deck, often include long runs of connection lines where standing water has been found to introduce a significant pressure differential.

Intek's pressure and temperature probes allow the measurement to be made within the steam space. An integrated temperature sensor is also used for saturation pressure validation. The instrument is installed through a ball valve assembly, which accommodates easy online maneuverability. These instruments are designed for long-term, reliable use in steam surface condenser performance monitoring applications, new condenser commission testing and short-term condenser performance evaluations.

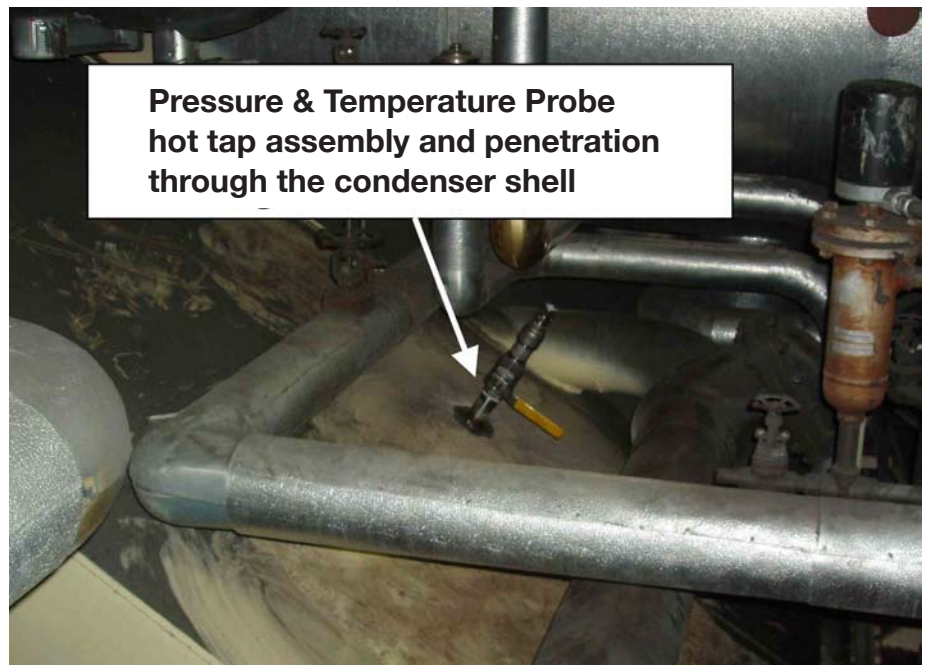

## Technical Services

Intek's condenser service engineers possess a unique and exclusive comprehension of condensers because of Intek's one-of-a-kind *RheoVac* and *Rheotherm* instruments. The engineering team at Intek has taken advantage of measured data to gain understanding of the condensation process through rigorous research and development. This team has measured and modeled the inadequacies of many condenser designs in hundreds of plants around the world and comprehensively understands the root causes of excess condenser pressure and condensate dissolved gases. Documented performance improvements from Intek-modified condensers provide proof of this unique knowledge.

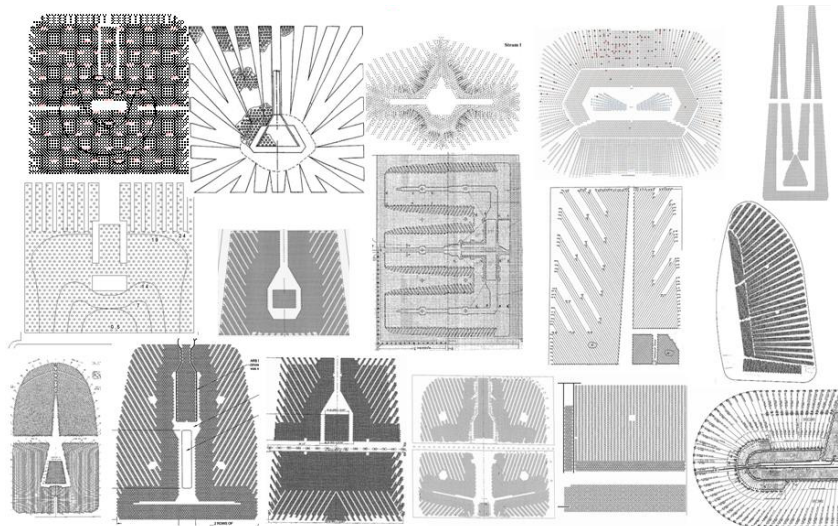

**Tailored Technical Assistance.** Intek manufactures the instruments necessary to implement a comprehensive condenser monitoring program. Technical support is available to assist you and answer questions regarding instrument use. The appropriate level of technical assistance and analysis is available to help get the most value from your instruments and solve your condenser performance issues. Web-accessible technical tools provide self-service methods for learning about condensers, analyzing data, and connecting to other users. Tailored technical assistance guides *RheoVac* and *Rheotherm* customers in getting the most value from these instruments through evaluating condenser operation and developing an action plan for improving condenser performance.

**Tailored Analytical Services.** Intek provides comprehensive services for system data review, modeling, and analysis. These services are tailored to the individual needs of customers and may include evaluating exhauster equipment, condenser performance evaluations, or even on-going operations monitoring. Customers with a Condenser Service contract submit available condenser operating data, including *RheoVac* Monitor data and *Rheotherm* Circulating Water Flow and Fouling Meter data, from which Intek engineers provide actionable recommendations to improve performance. The focus of this service is to: compare and validate *RheoVac* data with plant data; report findings as they relate to *RheoVac* operation, exhauster operations, air in-leakage, vacuum quality and other parameters as necessary; and provide troubleshooting and operational guidelines to improve condenser operations. Intek's condenser service team is standing by to assist with analysis and troubleshooting.

So many different condenser designs,  
but each has unique performance  
issues

## Technical Tools

Designed to help you help yourself, Intek's online graphing, forums, tutorials and case studies can simplify the task of analyzing measured *RheoVac* and *Rheotherm* data. This service, available at [www.MyCondenser.com](http://www.MyCondenser.com), provides customers with one place to submit and plot data in a meaningful way, learn diagnostic techniques from case studies, submit questions or chat with Intek engineers, and discuss best practices with peers.

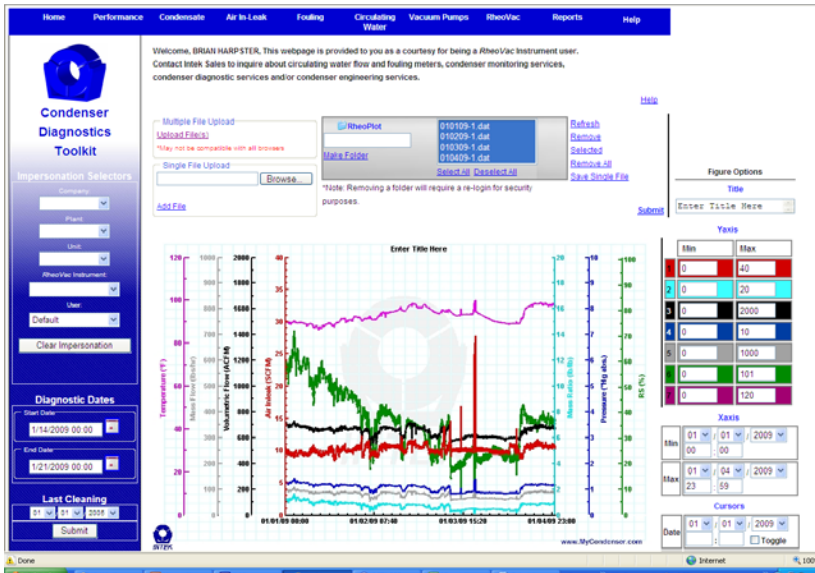

RheoPlot 7-axis graph available online

**RheoPlot.** Data can have little value unless it is viewed in a meaningful way. Intek has developed a 7-axis plot with data verification methods which is available online. Using these tools the data can be uploaded, plotted, printed and exported to various programs for professional and class presentations. The graphs and data can also be submitted to Intek for evaluation.

**Condenser Diagnostic Tutorials & Case Studies.** Learn how to use *RheoVac*, *Rheotherm*, and plant data to evaluate your condenser, practice to develop your own action items for improving condenser performance. Intek has published over 50 technical papers and reports through ASME, EPRI, ISA and other technical organizations. For reference, a listing of these papers is available at [www.IntekFlow.com](http://www.IntekFlow.com).

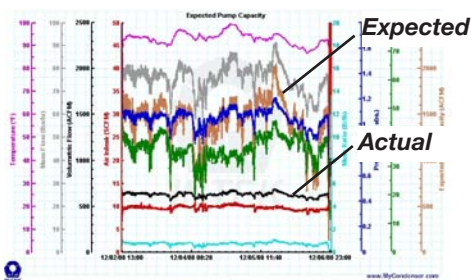

Exhauster Capacity

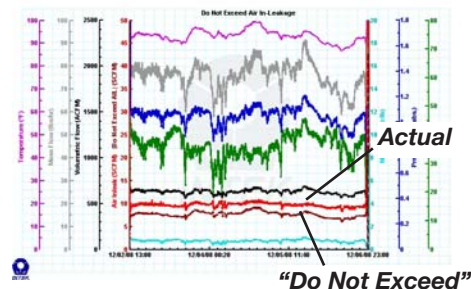

Air In-Leakage

## Exhauster Equipment Assessment

A common misconception is that LRVs and SJAEs are fixed capacity devices; in fact, their capacity is a strong function of the vent line gas-vapor mixture properties and operating conditions. Intek's Exhauster Equipment Assessment service provides *RheoVac* customers with the expected exhauster capacity based on actual model numbers and operating conditions. The assessment also provides a "do not exceed" air in-leakage value above which condenser pressure will increase. This information provides guidance in deciding to troubleshoot exhausters, run back-up exhausters, find and fix leaks, or do nothing.

**Example.** Exhauster capacity is an essential measurement for all condenser performance testing and monitoring programs. Without measuring exhauster capacity, there is no way to know if the maintenance action should focus on exhausters or air ingress. This case illustration confirms the NASH AT2006 pump is operating well below its rated capacity, resulting in excess condenser pressure. This customer now has the necessary information to direct a maintenance action to repair the exhauster and recover  $>0.2$ "Hg excess turbine back pressure.



## Tailored Analytical Services

Intek provides comprehensive analytical services including data analysis and modeling to evaluate exhauster equipment and condenser performance. Whether a one-time study or an ongoing evaluation program, a customized level of analysis is available to meet your needs. These services guide decision makers and managers looking to improve condenser performance and monitoring programs by identifying ways to improve existing practices and conditions through optimized operation and fast response maintenance.

**Operational Analysis.** This service can be used to provide analysis and guidance on specific issues, or to gain a long-term perspective over months of operations. Customers with this service submit condenser related data through a secure internet-accessible system using customized data templates. Intek then provides specific operations or maintenance action recommendations for condenser performance improvement. Ongoing analysis may be used to achieve and maintain optimal condenser performance by taking a long-term perspective of operational data, which may include scheduled condenser performance analysis and review of upset conditions. A report of findings and recommendations is updated on a scheduled basis. Intek experts continually review new data and the customer is alerted of significant performance-impacting issues. This service also helps the customer gain diagnostic insight that will enable them to take further advantage of Intek's online technical support and self-service diagnostic tools.

**Advanced Parametric Analysis.** This service utilizes Intek's integrated condenser monitoring system comprising *Rheotherm* and *RheoVac* instruments to gather and process otherwise difficult or unattainable data for the purpose of quantifying root-cause components of condenser performance deficiency. A detailed system analysis is performed using proven, proprietary analytical techniques to meet the intent of ASME PTC 12.2 for calculating the cleanliness factor and performance factor. These advanced methods quantify excess condenser pressure into six component sources: low circulating water flow, air in-leak, ineffective venting, design configuration, macrofouling, and microfouling. This instrumentation and analysis approach results in higher accuracy by removing assumptions and errors inherent to average value parameter condenser analysis methods.

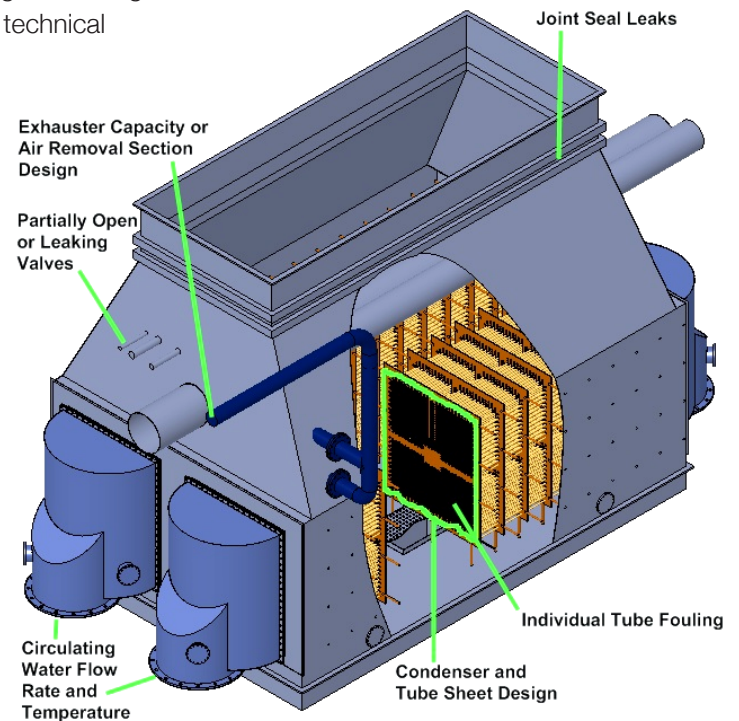

## Engineering Services

Intek provides solutions to plant engineers, chemists and managers having recognized difficult issues and decisions to be made, such as:

- Condenser re-tubing projects including tube size or material changes
- Chronic high DO or corrosion related to feedwater chemistry
- Historical lost load or future additional condenser duty
- Recognized poor condenser performance . . .

**Data & Drawing Review.** Intek reviews condenser drawings and various historical data as a first step in evaluating the customer-identified operating deficiencies. Potential causes for performance, condensate chemistry or operational problems are identified. It is often found that calibration of existing instrumentation or new instrumentation is necessary to conduct an accurate performance assessment.

**Condenser Inspection.** Intek engineers enter and inspect the condenser to confirm that drawings and as-is configuration are the same. Details of as-built condenser configuration are sometimes different from that which is shown in drawings. The inspection outage is also an opportunity to install additional instrumentation.

**Problem Analysis.** Intek provides evaluation of condenser performance as well as an assessment of potential performance improvement. Different improvement options with expected results are identified. Information to support a decision to proceed with an engineered retrofit design or to consider other corrective actions is provided in a comprehensive analysis report.

**Engineering.** A design concept is identified. The complete engineered solution is optimized. Established contractors perform construction services. Intek provides consultation, specification and procurement of materials, construction inspection and post start-up assistance to review quality of work and to quantify improvements.

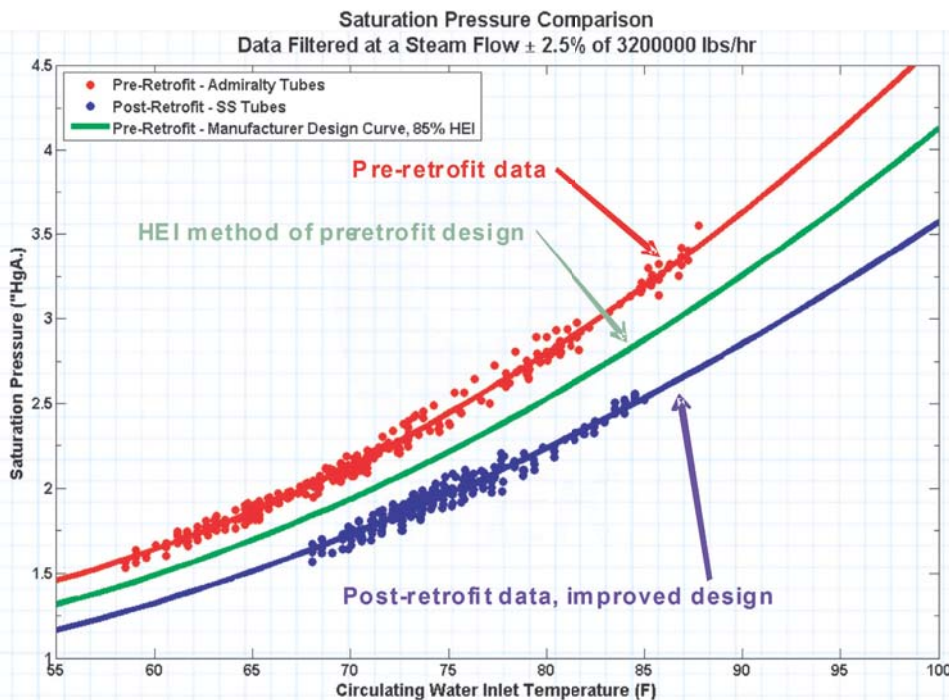

## Education and Training

Intek hosts Condenser Operations and Management Workshops for groups tasked with operating and maintaining Intek *RheoVac* monitors and *Rheotherm* CWFF meters, heat exchanger performance, or groups of people interested in improving fleet efficiency, chemistry, and operations.

This workshop will help plant personnel develop an understanding of condensers using data from modern instrumentation and learn how to use the data to diagnose problems and improve operations. The workshop explains why traditional limitations experienced with power plant condensers are no longer applicable. Major topics covered include:

**General Theory of Steam Surface Condensers.** A properly configured condenser should lower dissolved oxygen, never limit load, and aid in the efficient production of power. Learn how *RheoVac* measurements have advanced comprehension of the dynamics of gas and steam mixtures on the shell side of condensers. Examine the root cause mechanisms responsible for aeration and de-aeration, buildup of excess back pressure due to air storage or air ingress, and the dissolubility of corrosive gases in the condensate. Gain new insight into how condensers work and how this knowledge can be applied to lower condenser excess back pressure, reduce forced outages, enhance reliability, recover lost load and improve water chemistry.

***RheoVac* Instruments.** Learn all about *RheoVac* hardware, software, and outputs. Observe how Intek calibrates the instruments. Know what you can do to maintain reliable data and instrument performance.

***RheoVac* Data Evaluation and Diagnostics.** Learn how to get the most from your *RheoVac* instrument and troubleshoot your condenser system. Examples from existing *RheoVac* users are reviewed to highlight the full capability of the *RheoVac* system and teach you to effectively interpret the data to optimize condenser performance. Apply knowledge learned to solve condenser problems using *RheoVac* and actual plant data.

***Rheotherm* Circulating Water Flow & Fouling (CWFF) Instrument Diagnostics.** Learn how the CWFF meter enables plant personnel to monitor and troubleshoot the circulating water system using breakthrough technology that directly measures flow, outlet temperatures, and fouling in individual condenser tubes.

**Condenser Monitoring, Diagnostics and Solutions.** Learn to use workshop materials, *RheoVac* monitors and *Rheotherm* CWFF meters, and Intek's condenser services to improve condenser performance, facilitate fast response maintenance and optimize plant operations and availability.

On site training is also available.



## Intek, Inc: A History of Innovation

Dr. Joseph Harpster founded Intek, Inc. in 1976 with the goal of integrating technologies to solve complex measurement problems. An innovative flow metering solution for the oil industry led to development of Intek's *Rheotherm* line of instruments — meters and switches for liquids, gases and slurries.

The *Rheotherm* flow meter is the first patented instrument to accurately measure liquid flow rates using thermal methods. Especially suited to low flow applications, it is still the only technology to accurately measure real time flow rates as low as one gallon per year. Chemically compatible wetted surfaces and no moving parts further enhance the *Rheotherm* technology.

An innovative solution for the power industry led to development of Intek's *RheoVac* line of instruments and services for power plants. These instruments and services help plants optimize the operation of steam surface condensers, improving heat rate and reducing operating and maintenance costs.

Our team is dedicated to providing flow measurement solutions for difficult applications, and a high level of technical excellence and customer service. Our quality assurance program is annually certified to ISO 9001:2008.



**Contact Intek today to find out how our unique instruments and expertise can help you improve condenser performance, provide responsive maintenance support and optimize plant operations.**



**INTEK, INC.**  
751 Intek Way  
Westerville, OH 43082-9057  
Phone: 614-895-0301  
Fax: 614-895-0319  
sales@intekflow.com  
[www.intekflow.com](http://www.intekflow.com)

U.S. Patents: Nos. 5,485,754; 5,752,411; 6,526,755; 7,065,970, 7,926,277  
International patents; and pending patents  
INTEK, Rheotherm, and RheoVac are registered trademarks of INTEK, Inc.  
© 2012 by INTEK, Inc. Printed in U.S.A.